

Assembly and operating instructions

06.2022

Control FS 345 with FS 101 and CS 300 FS

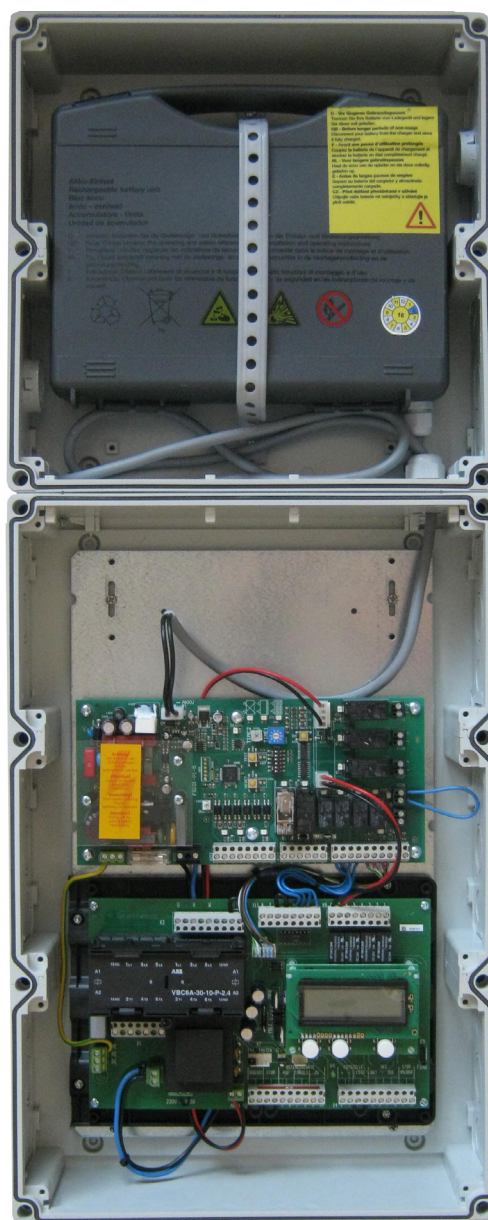

1. Contents

1.	Contents	2
2.	Information in this document	2
3.	General safety instructions	3
4.	Overview of products	4
5.	Commissioning	5
6.	Limit switches	16
7.	Programming with the LCD monitor	18
8.	Navigator (LCD monitor only)	20
9.	Overview of functions	22
10.	Rechargeable battery and battery charger	30
11.	Motor brake and auxiliary motor	34
12.	Technical data	36
13.	Maintenance	36
14.	EC Declaration of Incorporation	37

2. Information in this document

Original operating instructions

- Protected by copyright.
- No part of these instructions may be reproduced without our prior approval.
- Subject to alterations in the interest of technical progress.
- All dimensions are given in millimetres.
- The illustrations are not true to scale.

Meaning of symbols

DANGER!

Safety notice indicating a danger that will directly result in death or severe injury.

WARNING!

Safety notice indicating a danger that could result in death or severe injury.

CAUTION!

Safety notice indicating a danger that can result in slight or moderate injuries.

NOTICE

Safety notice indicating a danger that can result in damage to property or in irreparable damage to the product.

CHECK

Reference to a check that needs to be carried out.

REFERENCE

Reference to separate documents that must be observed.

 Instruction requiring action

- List, itemisation

→ Reference to other sections of this document

3. General safety instructions

DANGER!

Failure to comply with the documentation could result in life-threatening danger!

 Be sure to follow all the safety instructions in this document.

Warranty

The function and safety of the equipment is only guaranteed if the warning and safety instructions included in these operating instructions are adhered to.

Marantec Legden GmbH + Co. KG is not liable for personal injury or damage to property if these occur as a result of the warnings and safety advice being disregarded.

Marantec Legden does not accept any liability or warranty for damage due to the use of non-approved spare parts and accessories.

Intended use

The FS 345 control is intended exclusively for controlling door systems with mechanical limit switches.

Target group

Only qualified and trained electricians may connect, programme and service the control.

Qualified and trained electricians must meet the following requirements:

- Knowledge of the general and specific safety and accident prevention regulations,
- Knowledge of the relevant electrical regulations,
- Training in the use and care of appropriate safety equipment,
- Capable of recognising the dangers associated with electricity.

Instructions regarding installation and connection

- The control is designed with X type terminals.
- The control must be disconnected from the electricity supply before carrying out any electrical work. It must be ensured that the electricity supply remains disconnected for the duration of the work.
- Local protective regulations must be complied with.

Information concerning operation

- Unauthorised persons (particularly children) should not be allowed to play with permanently installed adjusting or control devices.
- Keep remote control beyond the reach of children.

Regulations and bases for testing

For connecting, programming and servicing, the following regulations must be observed (the list is not exhaustive).

Construction product standards

- EN 13241-1 (Products without fire resistance or smoke control characteristics)
- EN 12445 (Safety in use of power operated doors - Test methods)
- EN 12453 (Safety in use of power operated doors - Requirements)
- EN 12978 (Safety devices for power operated doors and gates - Requirements and test methods)

EMC

- EN 55014-1 (Electromagnetic compatibility - Requirements for household appliances)
- EN 61000-3-2 (Disturbances in supply systems - harmonic currents)
- EN 61000-3-3 (Disturbances in supply systems - voltage fluctuations)
- DIN EN 61000-6-2 (Electromagnetic compatibility (EMC) - Part 6-2: Generic standards – Immunity for industrial environments)
- DIN EN 61000-6-3 (Electromagnetic compatibility (EMC) - Part 6-3: Generic standards – Emission standard for residential, commercial and light-industrial environments)

Machinery Directive

- EN 60204-1 (Safety of machinery, electrical equipment of machines Part 1: General requirements)
- EN ISO 12100 (Safety of machinery – general principles for design - risk assessment and risk reduction)

General safety instructions

Low voltage

- DIN EN 60335-1 (Household and similar electrical appliances - Safety - Part 1: General requirements)
- DIN EN 60335-2-103 (Household and similar electrical appliances - Safety - Part 2-103: Particular requirements for drives for gates, doors and windows)

Committee for Workplaces (ASTA)

- ASR A1.7 (Workplace regulation "Doors and gates")

General safety instructions

- To enable fault-free operation to be guaranteed, it is imperative that the rechargeable battery be replaced after every two years of operation. If this maintenance instruction is disregarded, the functional safety of the system and thus also the safety of buildings and persons cannot be guaranteed.
- To ensure that the system always functions consistently, the fire alarm function must be checked once every four weeks. In order to check at the same time that the rechargeable battery also functions correctly, the control must be disconnected from the mains. In this way, the emergency function can be checked to ensure that the door is closed automatically by the auxiliary motor.
- Emergency operation is not possible if there is a fault in the safety circuit of the door operator.
- To avoid a deep discharge of the rechargeable battery, the battery should not be connected to the FS 101 unit until the system is put into operation for the first time. If deep discharge occurs, the battery cannot be recharged again and must be replaced immediately.

4. Overview of products

4.1 Product description

The FS 345 control can be used in connection with FDF, FT, FTA and FDS fire-protection drives as well as with hydraulic drives. In version FS 345 HY, hydraulic drives are used.

The FS 345 control consist of a CS 300 FS door control unit, an FS 101 auxiliary circuit board and a rechargeable battery for emergency power supply, magnetic couplings, DC-operated motors, 24V motor brakes.

In case of fire or power cuts, the emergency rechargeable battery provides the energy required for the auxiliary motor to close the door or for the motor brake to hold the door in position.

The fire mode is triggered by a continuous command in the fire alarm contact or is time activated if the mains power supply fails. In the case of fire, the door closes with the closing edge system deactivated, or, optionally, with the closing edge activated.

4.2 Various options

The following models of FS 345 control can be supplied:

- FS345 control for deadman operation
- FS345 control for automatic operation
- FS345 control for automatic operation with the closing edge system activated in the case of fire

The following housing models are available:

- Housing with OPEN - STOP - CLOSE buttons
- Housing with ON/OFF key switch
- Housing with main switch
- Housing with emergency OFF switch

The operating instructions describe the connection options and models of the FS 345 control.

4.3 Product drawing of CS 300 FS with FS 101

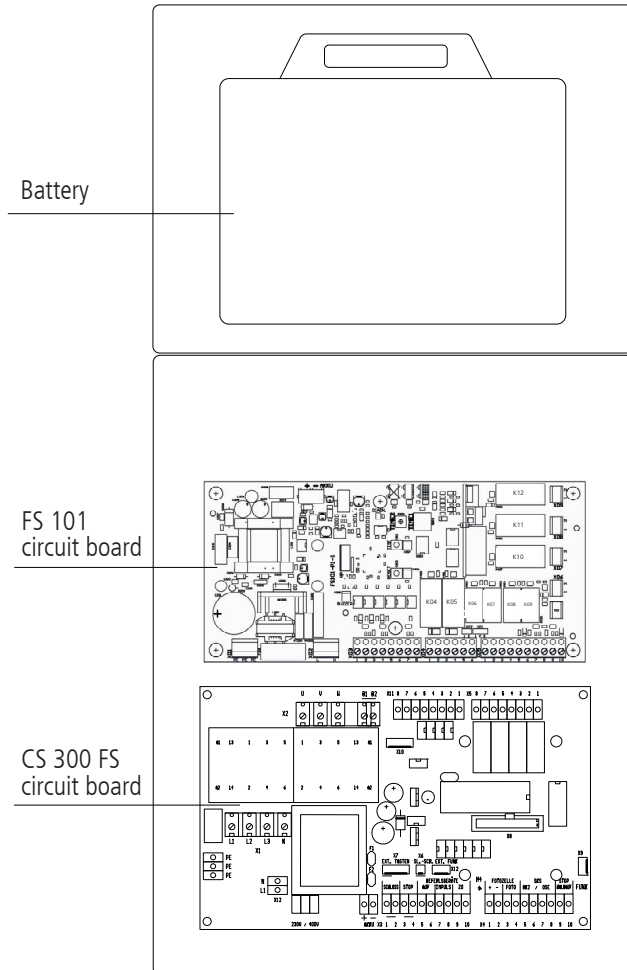

5. Commissioning

5.1 General information

To guarantee that the equipment functions properly, it must be ensured that:

- The door is installed and operational.
- The operator motor is installed and ready for operation.
- The command and safety devices are installed and ready for operation.
- The control housing with the FS 345 control is installed.

REFERENCE

The relevant manufacturers' instructions must be adhered to for the installation of the door, the Marantec Legden operator motor, and the command and safety devices.

5.2 Mains connection

Preconditions

To guarantee that the control function properly, the following points must be ensured:

- The mains voltage must correspond to the voltage stated on the type plate.
- The mains voltage must be the same as the voltage of the operator.
- For a three-phase current, a clockwise rotating field is required.
- For a permanent connection, an all-pole main switch must be used.
- For a three-phase connection, only 3-way automatic circuit breakers (10 A) may be used.

NOTICE

Malfunctions can occur as a result of incorrect installation of the control!

Before switching on the control for the first time, a check must be carried out after completing the wiring to ensure that all the motor connections at the motor and at the control is securely fixed. All control voltage inputs are galvanically isolated from the supply.

Initial operation

5.3 Initial operation FS 101 emergency operation circuit board

General

The FS 101 circuit board includes a charger for the rechargeable battery and a microprocessor for controlling the auxiliary drive or the motor brake.

The circuit board is connected to the CS 300 FS door control unit in the factory and if it is purchased together with a door operator, the correct settings for that operator are also preset in the factory.

All that remains to be connected is a fire alarm, and the rechargeable battery must be connected to the FS 101 circuit board via a plug.

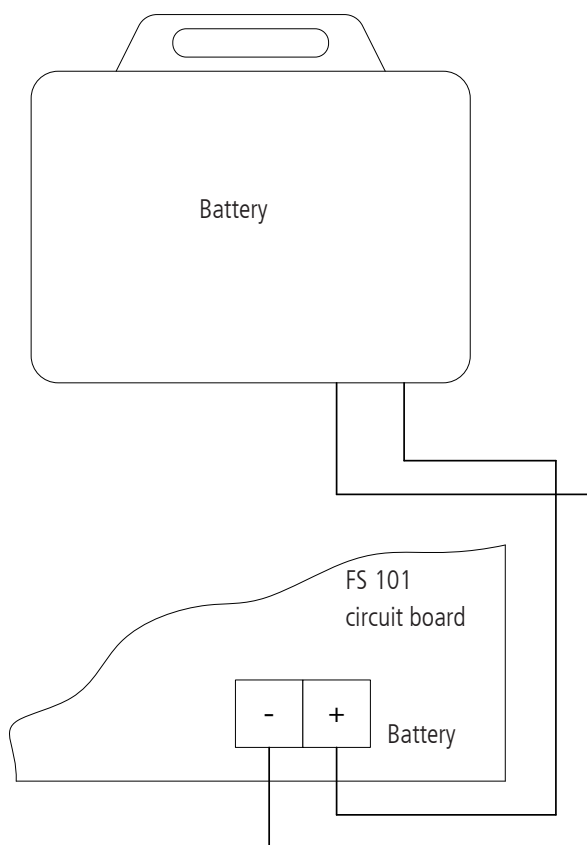

NOTICE

Malfunctions due to incorrect installation of the battery!

To prevent deep discharge of the rechargeable battery, the battery should not be connected to the FS 101 circuit board until the door is put into operation. To prevent errors, the battery must be connected to the FS 101 circuit board before the connection is made to the mains power supply.

5.4 Circuit diagram for mains connection and motor

CS 300 FS

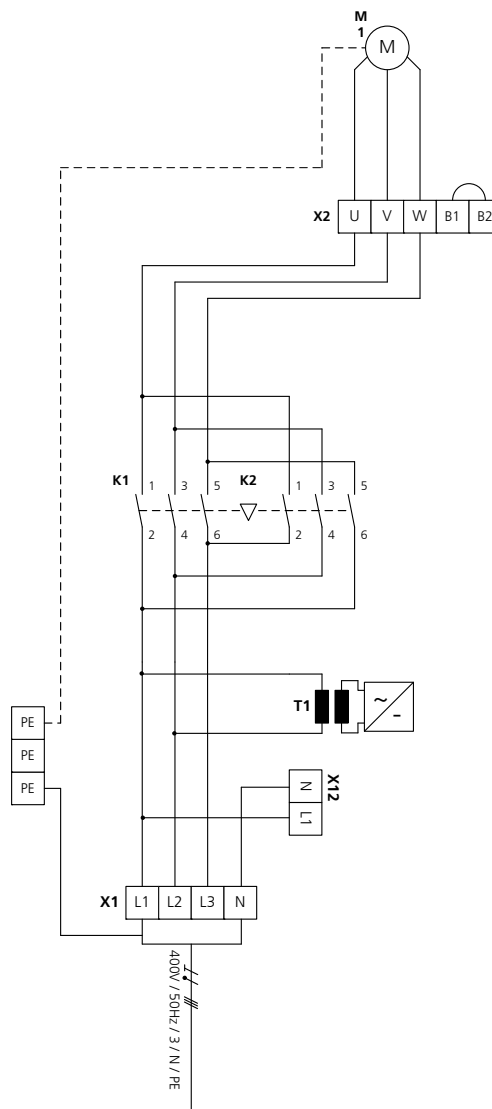

Key:

- K1: CLOSE contactor
- K2: OPEN contactor
- M1: Motor
- T1: Transformer
- X1: Terminal block for mains connection
- X2: Terminal block for motor

Connection:

- Connect the control to the mains power supply.
- Connect the control to the motor.
- Cable groups must be secured close to their relevant terminals using a cable tie.

FS 101 - CS 300 FS (ready-wired)

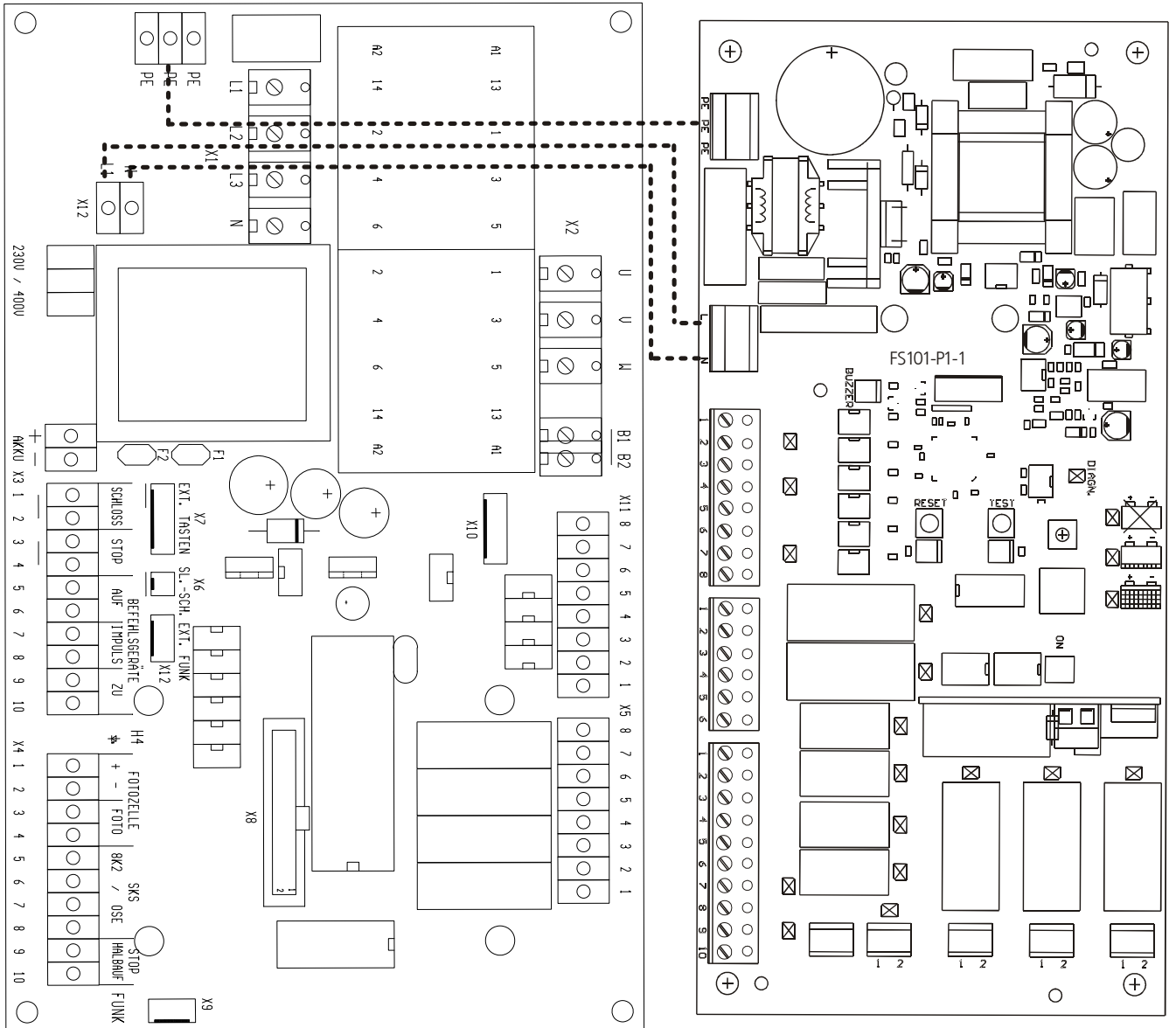

Initial operation

5.5 Mains power connection and motor 230 V AC version

CS 300 / FS 230 V AC, 3~

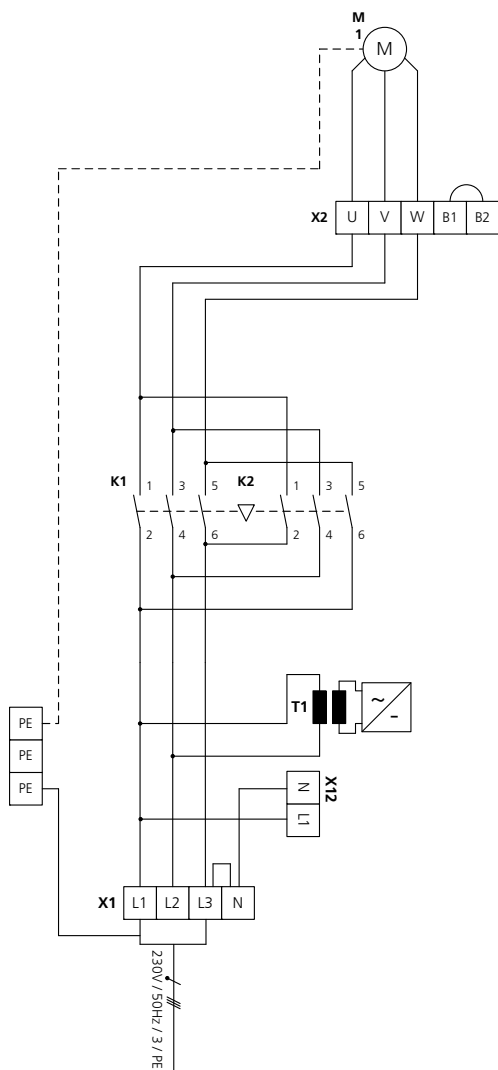

Key:

- K1: CLOSE contactor
- K2: OPEN contactor
- M1: Motor
- T1: 230 V transformer
- X1: Terminal block for mains connection
- X2: Terminal block for motor

Connection:

- Connect the control to the mains power supply.
- Connect the control to the motor.
- Cable groups must be secured close to their relevant terminals using a cable tie.

CS 300 / FS 230 V AC, 1~

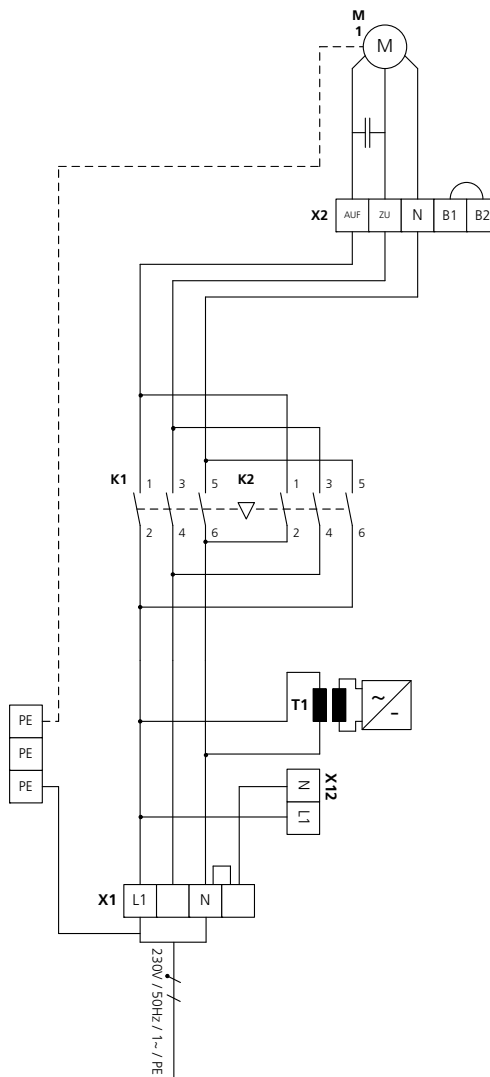

Key:

- K1: CLOSE contactor
- K2: OPEN contactor
- M1: Motor
- T1: 230 V transformer
- X1: Terminal block for mains connection
- X2: Terminal block for motor

Connection:

- Connect the control to the mains power supply.
- Connect the control to the motor.
- Cable groups must be secured close to their relevant terminals using a cable tie.

5.6 Connection of command and safety devices for normal door operation X3/CS 300 FS

Command and safety devices can be connected via terminals X3 and X4.

X3 / CS 300 FS

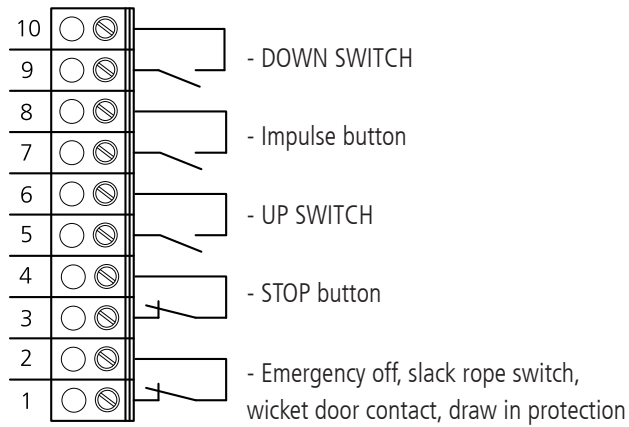

X6 / CS 300 FS

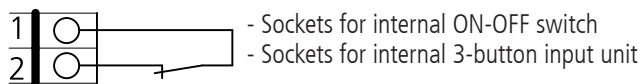

X7 / CS 300 FS

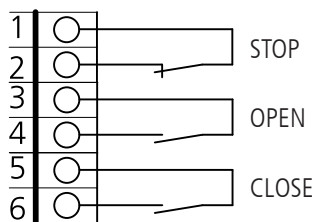

Initial operation

5.7 Connection examples for command and safety devices (terminal block X3/CS 300 FS)

OPEN / STOP / CLOSE buttons

(6-lead solution)

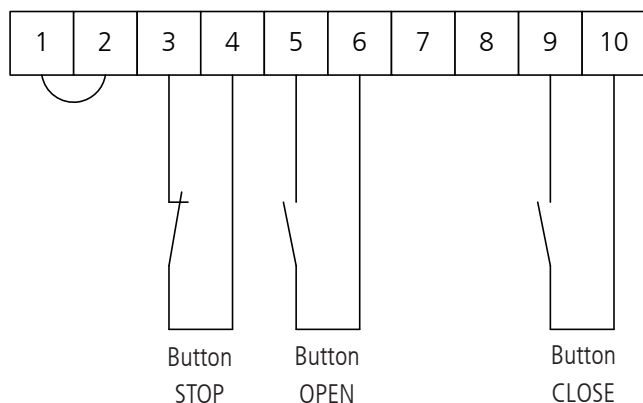

UP / DOWN key switch

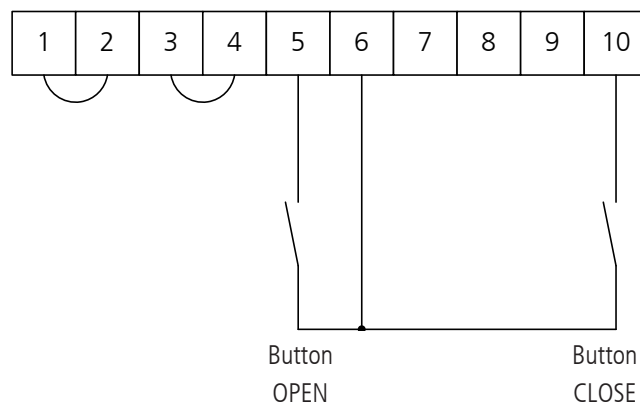

OPEN / STOP / CLOSE buttons

(4-lead solution)

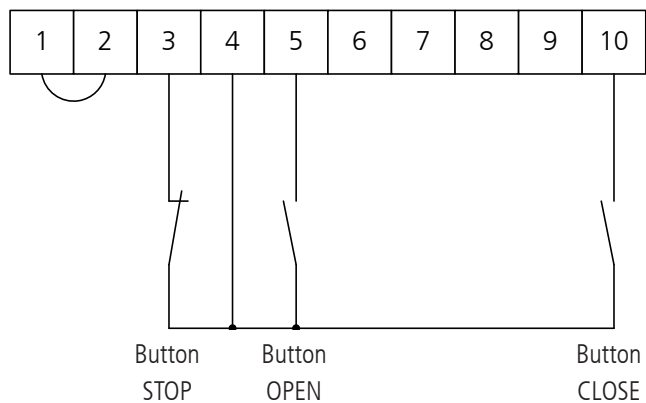

Impulse button key switch

(sequence control)

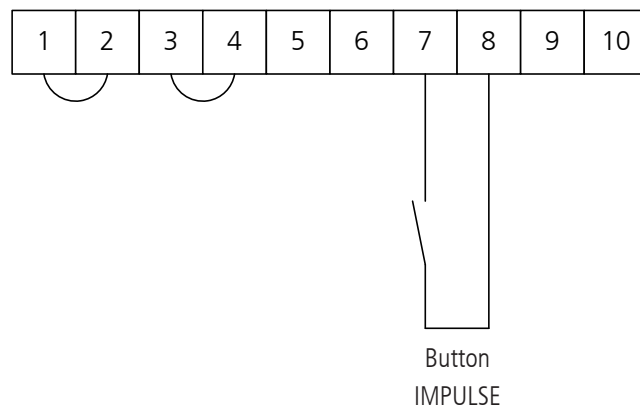

5.8 Connection examples for safety devices X4/CS 300 FS

Terminal block X4

8.2 kOhm closing edge safety device

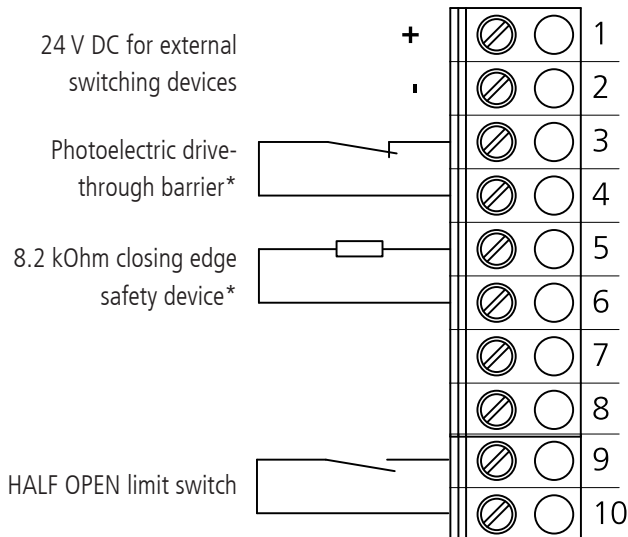

Terminal block X4

Optoelectronic closing edge safety system

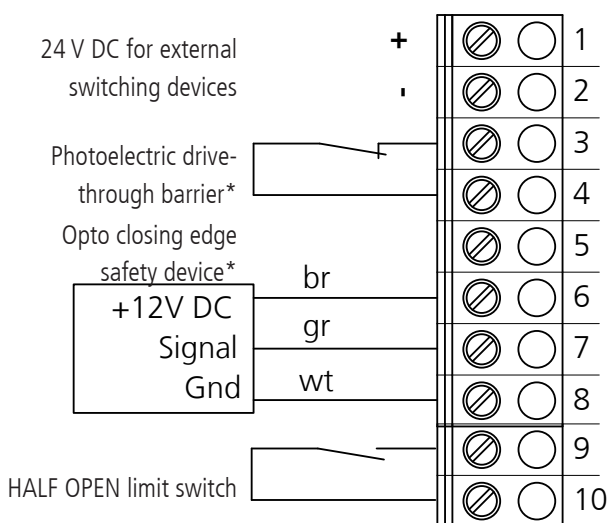

Terminal block X4

Pneumatic safety edge protection - pressure sensor test

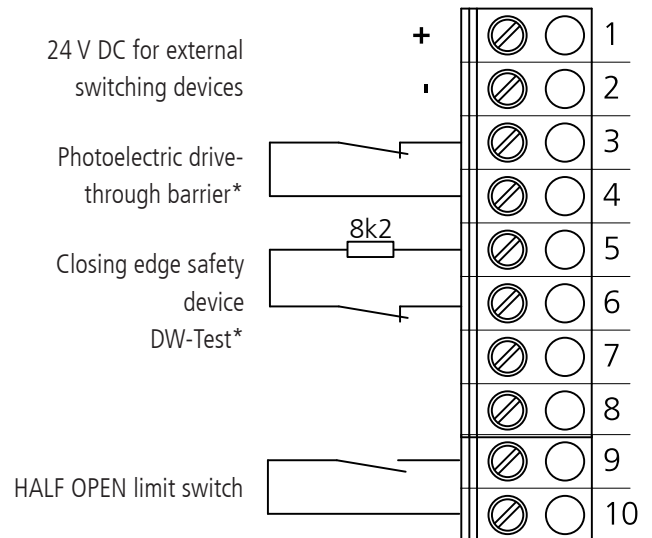

Terminal block X4

Marantec Legden-type leading photoelectric barrier

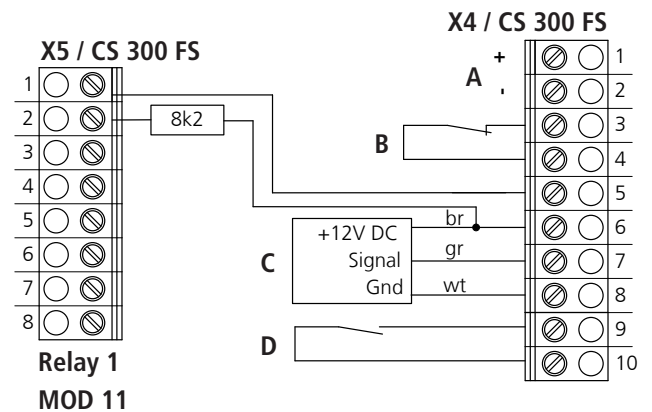

- A 24 V DC for external switching devices
- B Drive-through photoelectric barrier*
- C Leading photoelectric barrier
- D HALF OPEN limit switch

Adjustment of the pre-limit switch CLOSE for the leading photoelectric barrier

- On the CS 300 FS, set the mode for relay 1 to 11 (pre-limit switch CLOSE)
- Drive the door in the "close" direction until the leading photocell just touches the ground.
- In the input menu, set the pre-limit switch CLOSE to this position

* effective in down direction only

Initial operation

5.9 Product drawing of FS 101 circuit board + rechargeable battery

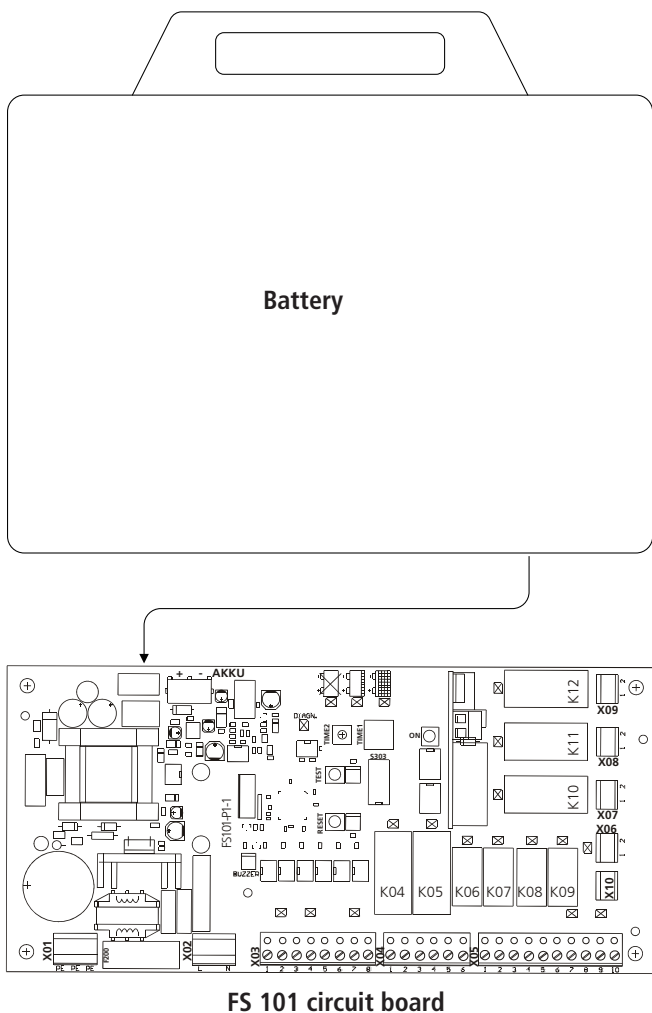

Key to FS 101 circuit board

X01/ X02	Power supply 230V / PE
X03	Limit switch connection
X04	Outputs for the auxiliary motor, brake, auxiliary relay
X05	Activation of the CS 300 FS circuit board
X06	Fire alarm connection
X07	Potential-free output for fault indicator
X08	Potential-free output for fire alarm
X09	Potential-free output for closing edge safety device
X10	Input, external 24 V
+ -BATT	Terminal block for battery pack
Time 1	Time-controlled closing if mains power supply fails
Time 2	Timing element for door seal function
S303	DIP switch
Reset	Button – switch off buzzer
Test	Button for testing emergency operation
F200	3.15 A fuse for battery charger
ON	Button
K04	Auxiliary motor relay
K05	Motor brake relay
K06	OPEN/CLOSE command relay
K07	Upper switch relay
K07	Lower switch relay
K09	Stop relay
K10	Operation / error relay
K11	Emergency closing relay
K12	Closing edge safety device (SKS) relay

5.10 DIP switches:

- 1 ON Door operator types FT (+ HY)*
- 1 OFF Door operator types FDF + FTA
- 2 ON Fire alarm as normally open contact
- 2 OFF Fire alarm as normally closed contact
- 3 ON Emergency closing with 400V AC / 24 VDC
- 3 OFF Emergency closing with 24V DC
- 4 ON With CESD (SKS) in emergency operation
- 4 OFF Without CESD (SKS) in emergency operation
- 5 ON Door closes if an error occurs
- 5 OFF Door remains open if an error occurs
- 6 ON (Operator type HY)*
- 6 OFF Operator type FT

When making changes to the DIP switch settings, the following procedure must be observed:

1. Switch off the mains voltage
2. Switch off the rechargeable battery voltage
3. Change the DIP switch positions as required
4. Switch on the rechargeable battery voltage
5. Switch on the mains voltage

* version HY only

5.11 Types of door operator

The FS 345 control is designed for use with two different types of door operator.

FT operators

- DIP 1 ON and DIP 6 OFF
1. FT door operators with 24V DC motor braking.
- In emergency mode, the door is closed via the 24V DC auxiliary motor.
- The weight of the door is held by the energised motor brake.
- The power supply comes from the mains adapter on the FS 101 circuit board; if the mains power is interrupted, power is supplied from the rechargeable battery.
- (DIP 6 ON required for version HY)



FD (FDF, FTA, FDS) operators

- DIP 1 OFF
1. FD (FDF, FTA and FDS) door operators with a 24V DC auxiliary motor and 24V DC motor brake (FDF 5). In emergency mode, the door is closed via the 24V DC auxiliary motor.
- The power supply comes from the mains adapter on the FS 101 circuit board; if the mains power is interrupted, power is supplied from the rechargeable battery.

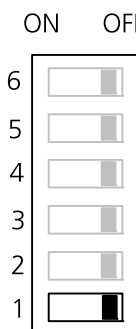

Initial operation

5.12 FS 101 connections

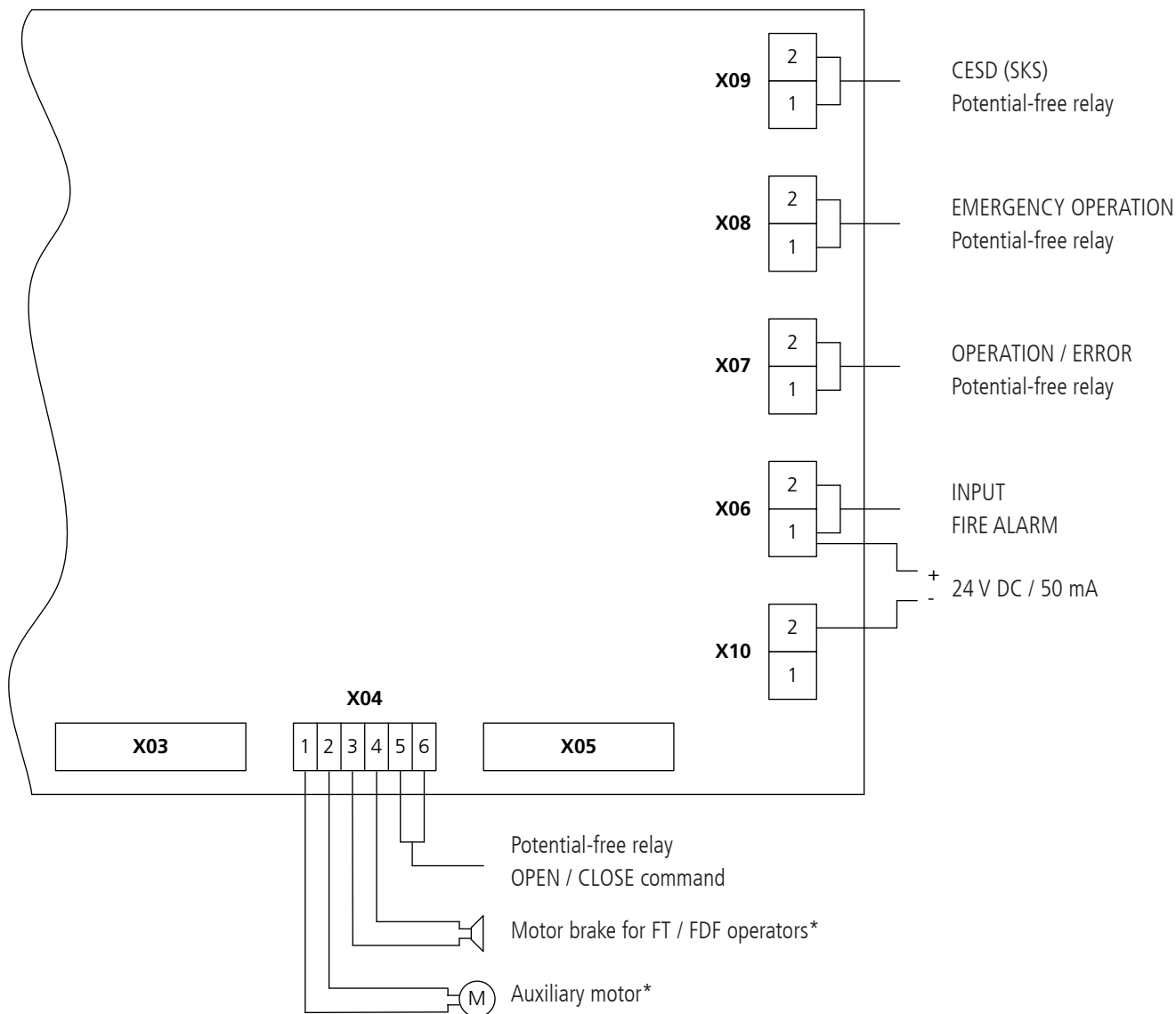

* refer to the appendix for connection details for operators FT 3 and FDF 60

5.13 Connection example for fire alarm contact

Terminal strip X06

(potential-free continuous contact as normally closed contact)

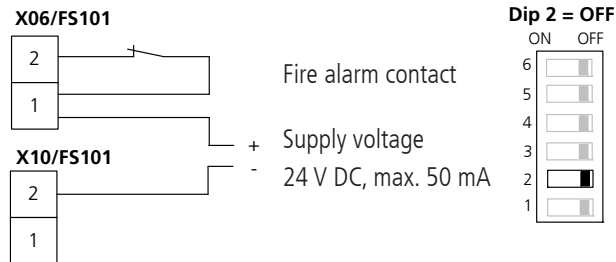

Terminal strip X06

(potential-free continuous contact as normally open contact)

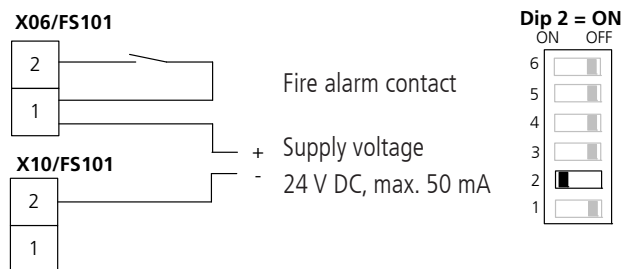

5.14 Messages

Terminal strip X07

K10 operation / error relay

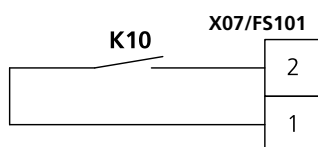

In normal operation contact closed, opens in the event of an error.

Rechargeable battery fault / mains power failure: switches if the battery is defective or if the battery voltage is less than 19V.

Terminal strip X08

K11 emergency closing relay

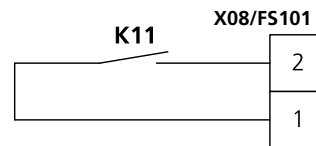

Potential-free switching contact for emergency operation is active. Switches in the event of emergency closing (contact closed).

Terminal block X4

K06 operator command relay

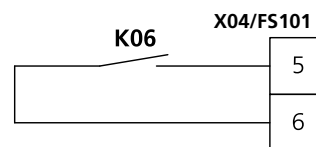

Potential-free switching contact for CLOSE or OPEN command depending on DIP switches 1 and 3.

(See 12 and 13.1 for wiring and function)

Terminal strip X09

K12 closing edge safety edge (SKS) relay

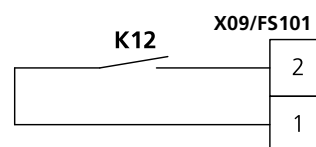

Potential-free switching contact, displays status of CESD (SKS)

6. Limit switches

6.1 Limit switches

Connection arrangement for limit switches (CS 300 terminals X11, X10 and FS 101 terminals X03, X05)

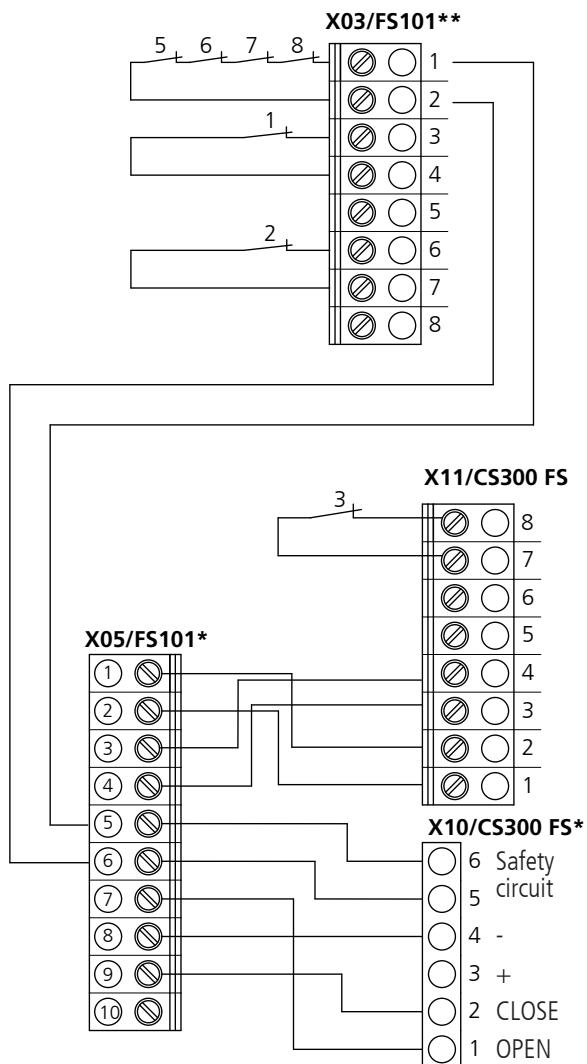

- 1 Limit switch OPEN
- 2 Limit switch CLOSE
- 3 Pre-limit switch CLOSE
- 5 Thermal protection, motor*
- 6 Emergency operation (normally closed contact)**
- 7 Safety limit switch CLOSE
- 8 Safety limit switch OPEN

* ready wired

** ready wired if supplied with operator

The limit switches (with the exception of the pre-limit switch) are analysed by the FS101 circuit board, and the values are passed on to the CS 300 FS circuit board.

☞ The assignment of terminal X11 (limit switch) is different from the assignment given to terminals in the AS 130. This must be taken into account in the event of retrofits

6.2 FDF / FTA / FDS limit switch settings

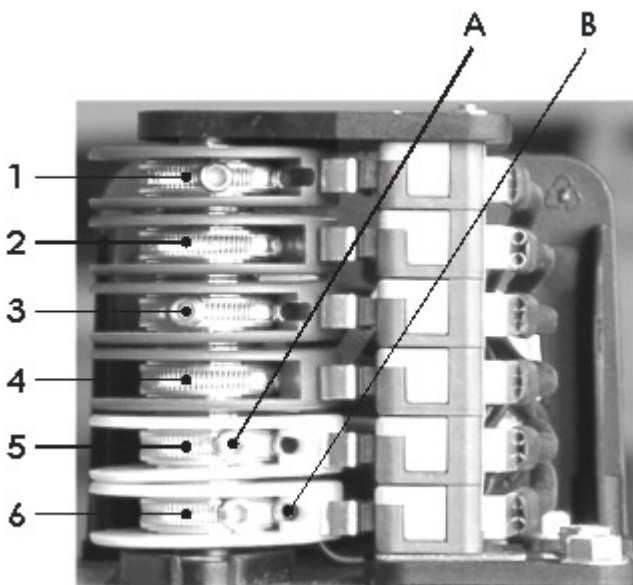
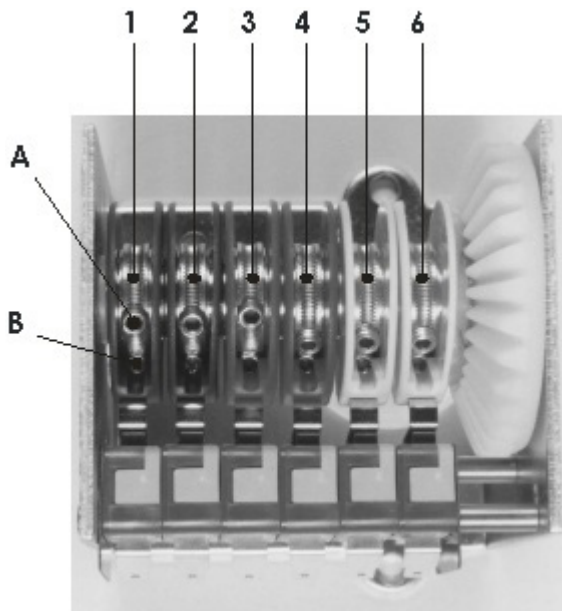

- | | | |
|----|--------------------------------|-------|
| 1. | Additional OPEN limit switch | green |
| 2. | Limit switch OPEN | green |
| 3. | Safety limit switch OPEN | red |
| 4. | Safety limit switch CLOSED | red |
| 5. | Limit switch CLOSED | white |
| 6. | Additional limit switch CLOSED | white |

NOTICE

Damage to property or irreparable damage due to incorrect adjustment!

The door can be damaged if it is driven beyond the end position while adjustments are being made.

1. Select the ADJUSTMENT menu on the display
2. Move the door to the desired CLOSED position with the + and - buttons.
3. Set control cam 5 (white) so that the limit switch is actuated.
4. Tighten fastening screw A.
5. Screw B can be used to carry out fine tuning.
6. Move the door to the desired OPEN position with the + and - buttons.
7. Set control cam 2 (green) so that the limit switch is actuated.
8. Tighten fastening screw A.
9. Safety limit switches 3 and 5 (red) must be set so that they are triggered as soon as the control limit switches are crossed.
10. After the trial run, check the tightness of the fastening screws.
11. Auxiliary limit switches 1 and 6 have a potential-free changeover contact

Limit switches

6.3 FT limit switch settings

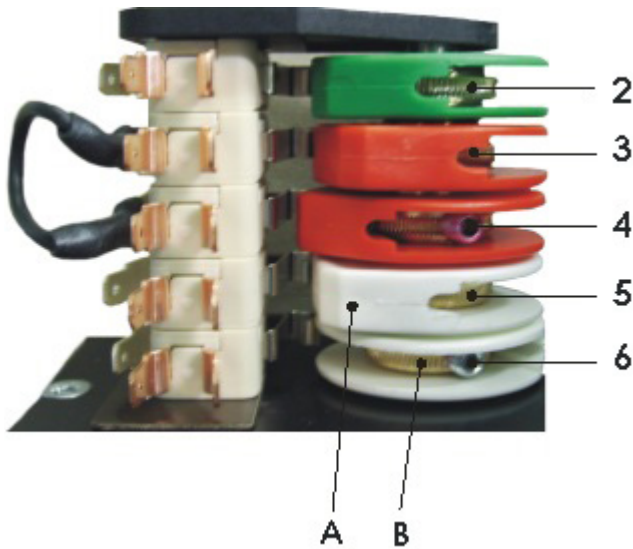

- | | |
|----------------------------------|-------|
| 2. Limit switch OPEN | green |
| 3. Safety limit switch OPEN | red |
| 4. Safety limit switch CLOSED | red |
| 5. Limit switch CLOSED | white |
| 6. Auxiliary limit switch CLOSED | white |



NOTICE

Damage to property or irreparable damage due to incorrect adjustment!

The door can be damaged if it is driven beyond the end position while adjustments are being made.

1. Select the ADJUSTMENT menu on the display
2. Move the door to the desired CLOSED position with the + and - buttons.
3. Set control cam 5 (white) so that the limit switch is actuated.
4. Tighten fastening screw A.
5. Screw B can be used to carry out fine tuning.
6. Move the door to the desired OPEN position with the + and - buttons.
7. Set control cam 2 (green) so that the limit switch is actuated.
8. Tighten fastening screw A.
9. Safety limit switches 3 and 4 (red) must be set so that they are triggered as soon as the control limit switches are crossed.
10. After the trial run, check that the fastening screws are correctly tightened.
11. Auxiliary limit switches 1 and 6 have a potential-free changeover contact

7. Programming with the LCD monitor

7.1 Overview of the LCD monitor

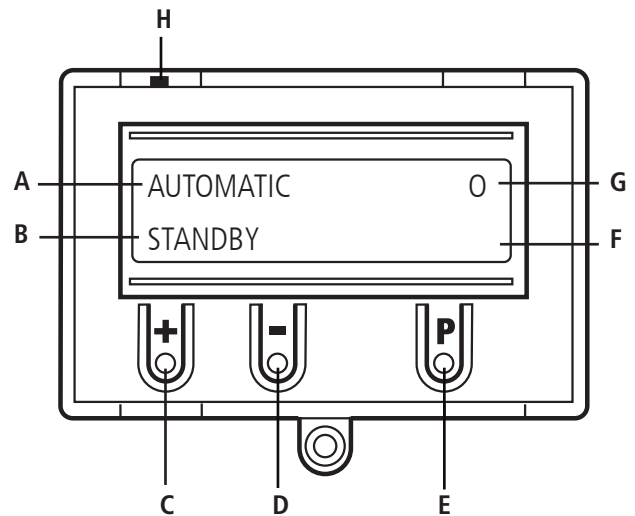

Key:

- | | |
|----|------------------------------------|
| A: | Mode of operation / DIAGNOSIS info |
| B: | Parameters / DIAGNOSIS info |
| C: | Button (+) |
| D: | Button (-) |
| E: | Button (P) |
| F: | Value / status |
| G: | Value / status |
| H: | Jumper |

7.2 LCD monitor, modes of operation

The control has four modes of operation with the LCD monitor:

1. AUTOMATIC
2. ADJUSTMENT
3. INPUT
4. DIAGNOSIS

If jumper H is removed, the (+) button, the (-) button and the (P) button have no function.

The display still functions.

After switching the control on, it is in INITIALISATION mode.

The display shows INIT PHASE and the control is not yet ready for use. This phase lasts approx. 5 seconds.

ADJUSTMENT, INPUT and DIAGNOSIS modes are exited automatically 20 seconds after the last button was pressed, and the control then goes into AUTOMATIC mode.

Operating mode 1: AUTOMATIC

The door system is operated in AUTOMATIC operating mode.

Display:

- Displays the action being carried out
- Displays any errors

If the "PRESS/REL" parameter is set to MOD2 or MOD3 in the input menu, the display changes from AUTOMATIC to MANUAL.

Operating mode 2: ADJUSTMENT

In ADJUSTMENT mode, the OPEN/CLOSED end positions are set.



NOTICE

Malfunctions can occur as a result of incorrect operation of the control!

In ADJUSTMENT mode, the door will not stop automatically when it reaches the travel limit position if electronic end positions (AWG) are used.

The door can be damaged if driven beyond the end position.

Fine adjustments can be made in the INPUT operating mode.

Display:

- Displays the travel limit value

Operating mode 3: INPUT

In the INPUT operating mode, the values of various parameters can be altered.

Display:

- Displays the selected parameter
- Displays the current value or status

Operating mode 4: DIAGNOSIS



In the DIAGNOSIS operating mode, door-specific checks can be queried.

Display:

- Displays the monitored function
- Displays the status of the function

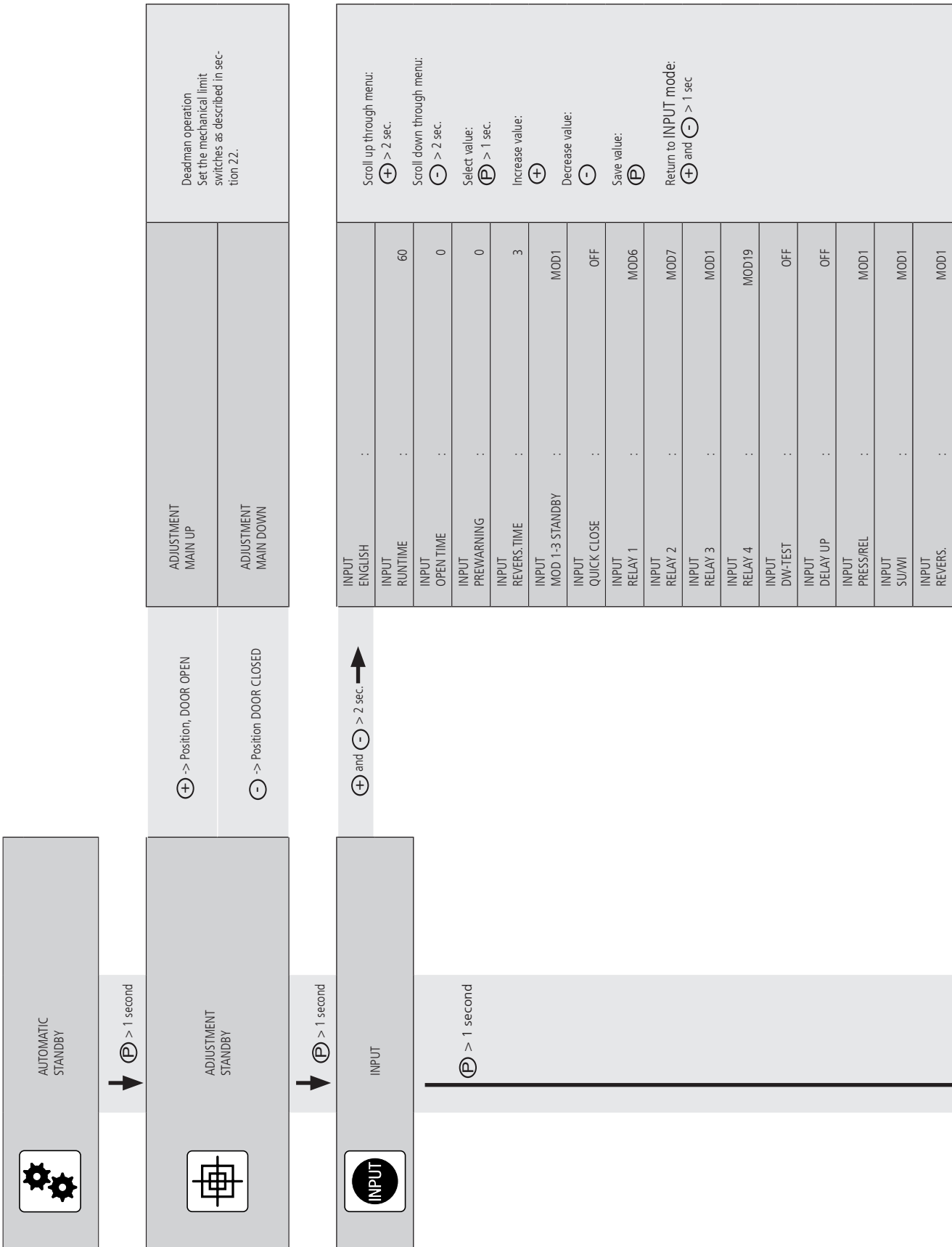
8. Navigator (LCD monitor only)



DIAGNOSIS		Scroll up through menu:  > 2 sec. Scroll down through menu:  > 2 sec. Return to AUTOMATIC mode:  Only queries are possible.
UPPER SWITCH	:	ON
LOWER SWITCH	:	OFF
UP SWITCH	:	OFF
PART UP	:	OFF
DOWN SWITCH	:	OFF
SKS	:	OFF
IMP. INPUT	:	OFF
SWITCH CLOCK	:	OFF
LIGHT BARR.	:	ON
STOP CIRCUIT	:	ON
S-POINT1	:	ON
S-POINT2	:	ON
CYCLE	:	XXXX

9. Overview of functions

9.1 Automatic operating mode

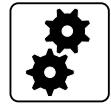

Display	Description
AUTOMATIC OPEN	The door is driven to the OPEN end position
AUTOMATIC CLOSE	The door is driven to the CLOSED end position
AUTOMATIC STANDBY	The door stands between the end positions
AUTOMATIC O STANDBY	The door stands at the OPEN end position
AUTOMATIC o STANDBY	The door stands at the PART OPEN position ("before-end position" up)
AUTOMATIC U STANDBY	The door stands at the CLOSED end position
AUTOMATIC u STANDBY	The door stands at the PART CLOSED position ("before-end position" down)

9.2 Input operating mode



Function	Description	Setting options	Factory settings
GERMAN	Select the menu language	DEUTSCH ENGLISH FRANCAIS NEDERLANDS ESPANOL POLSKI CESKY	DEUTSCH
RUNTIME	Monitoring the maximum running time for an open and closing movement.	1 – 250 seconds	60 seconds
OPEN TIME	After the door has opened, it runs back in the CLOSE direction after the set time has elapsed. Open time > 0 = impulse functions only work in the OPEN direction	0 – 600 seconds	0 = Auto close off
PREWARNING	The warning light flashes before the door starts to close. The preset warning time is only active if the open time is > 0 or if operated via radio impulse.	0 - 120 seconds	0 = Off
REVERS. TIME	Standing time at every change of direction	0.1 - 2.0 seconds (in 1/10 seconds)	0.3 seconds
MOD 1-3 STANDBY	MOD1: When resting OFF MOD2: When resting ON	MOD1 MOD2	MOD1
QUICK CLOSE	ON: The open time is cut short after the photoelectric barrier has been passed (door closes immediately). OFF: The open time continues as usual.	ON OFF	OFF
RELAY 1	A relay module from 1 - 18 can be assigned to the first three relays. MOD1: Red light is on during door movement and flashes as advanced warning MOD2: Red light flashes during door movement and flashes as advanced warning MOD3: Red light flashes during door movement and flashes as advanced warning The parameter M3-1 STAND. affects these 3 MOD. MOD4: Impulse when there is an OPEN command	MOD1 – MOD18	MOD6
RELAY 2	MOD5: Error message MOD6: OPEN end position MOD7: CLOSED end position MOD8: OPEN end position negated MOD9: CLOSED end position negated MOD10: Before-end position OPEN	MOD1 – MOD18	MOD7
RELAY 3	MOD11: Before-end position CLOSED MOD12: Before-end position CLOSED to CLOSED end position MOD13: Magnetic lock function MOD14 Brake MOD15: Brake negated MOD16: Brake remains ON during open time MOD17: Brake remains ON during open time and direction turnaround (with a CESD (SKS) the brake is deactivated) MOD18: Red light flashes as a warning	MOD1 – MOD18	MOD1
RELAY 4	MOD19: CESD (SKS)	MOD 19	MOD19
DW-TEST	ON: Pressure switch testing is active OFF: Pressure switch testing is not active	ON OFF	OFF
DELAY OPEN	ON: Gives warning before opening OFF: Immediate opening	ON OFF	OFF

Overview of functions

Function	Description	Setting options	Factory settings
PRESS/REL	MOD1: Automatic operation MOD2: Manual operation for OPEN + CLOSE MOD3: Manual operation for CLOSE	MOD1 – MOD2	MOD1
SU/WI	MOD1: PART OPEN at terminal block X4 (9/10) MOD2: PART OPEN selector switch at terminal block X4 (9/10) When the selector switch is closed, all OPEN commands go to the pre-limit switch OPEN.	MOD1 – MOD2	MOD1
REVERS.	MOD1: The door does not reverse when the pre-limit switch CLOSE is activated. MOD2: The door does not reverse, even if the pre-limit switch CLOSE is activated.	MOD1 – MOD2	MOD1
SEP LEADING	MOD1: No function MOD2: Leading photoelectric barrier (Marantec Legden)	MOD1 – MOD2	MOD1

9.3 Diagnosis / error memory operating mode



Display	Meaning	Status
UPPERSWITCH	OPEN end position	OFF: activated ON: not activated
LOWERSWITCH	CLOSED end position	OFF: activated ON: not activated
UP SWITCH	UP switch	ON: activated OFF: not activated
PART OPEN	PART OPEN button	ON: activated OFF: not activated
DOWN SWITCH	DOWN SWITCH	ON: activated OFF: not activated
SKS	Closing edge safety device	ON: circuit closed OFF: interrupted (fault)
IMPULSE	Impulse button	ON: activated OFF: not activated
SWITCH CLK.	Weekly timer	ON: activated OFF: not activated
LIGHT BARR.	Photoelectric drive-through barrier	ON: circuit closed OFF: interrupted (fault)
STOP CIRCUIT	- Stop button on the control - Stop systems in the operator	ON: circuit closed OFF: interrupted (fault)
S-POINT1	- Stop button on the control (keypad on cover)	OFF: activated ON: not activated

Display	Meaning	Status
S-POINT2	Pre-limit switch CLOSE	OFF: activated ON: not activated
CYCLE	Door cycle counter	Displays number of door cycles

9.4 LED indications of the FS101

The FS 345 control unit is equipped with a row of LEDs that indicate the current operating status of the system and indicate any faults that may occur. The following table gives an overview of the various faults and status conditions.

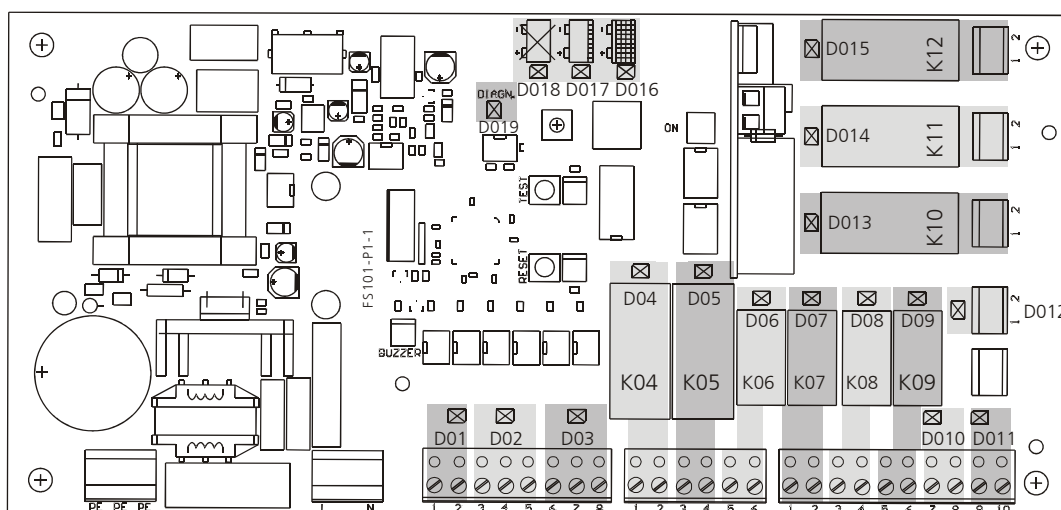

9.5 LED diagnostic FS 101

Code	Colour	Description		Error diagnosis
D01	yellow	LED safety circuit (input X03/1,2)	LED ON LED OFF	OK - No power supply from mains or rechargeable battery - Operator safety circuit interrupted
D02	yellow	LED limit switch OPEN (input X03/3,4,5)	LED ON LED OFF	Limit switch OPEN not confirmed Limit switch OPEN confirmed
D03	yellow	LED limit switch CLOSED (input X03/6,7,8)	LED ON LED OFF	Limit switch CLOSED not confirmed Limit switch CLOSED confirmed
D04	yellow	LED auxiliary motor (output X04/1,2)	LED ON LED OFF	Auxiliary motor is active Auxiliary motor 24V DC is not active
D05	yellow	LED motor brake (output X04/3,4)	LED ON LED OFF	Motor brake is switched on Motor brake is switched off
D06	yellow	LED drive command open/ close (output X04/ 5,6)	LED ON LED OFF	Drive command open/close on CS 300 FS is active Drive command open/close on CS 300 FS is not active

Overview of functions

Code	Colour	Description		Error diagnosis
D07	yellow	LED limit switch OPEN (output X05/1,2)	LED ON LED OFF	Limit switch OPEN not confirmed - Limit switch OPEN confirmed - Emergency operation is active
D08	yellow	LED limit switch CLOSED (output X05/3,4)	LED ON LED OFF	Limit switch CLOSED not confirmed Limit switch CLOSED confirmed
D09	yellow	LED stop circuit (output X05/5,6)	LED ON LED OFF	OK - No power supply from mains/rechargeable battery - Safety circuit on drive unit interrupted - Emergency operation is active
D010	yellow	LED CS 300 FS OPEN (input X05/7,8)	LED ON LED OFF	Door is moving towards OPEN in 400V operation Door is not moving towards OPEN in 400V operation
D01	yellow	LED CS 300 FS OPEN (input X05/9,10)	LED ON LED OFF	Door is moving towards CLOSED in 400V operation Door is not moving towards CLOSED in 400V operation
D012	yellow	LED fire detector (input X06/1,2)	LED ON LED OFF	Fire detector is closed Fire detector is open (observe DIP 2)
D013	yellow	LED operation / fault (output X07/3,4)	LED ON LED OFF	Operation / no fault Battery fault, mains
D014	yellow	LED emergency operation (output X08/1,2)	LED ON LED OFF	Emergency operation is active Emergency operation is not active
D015	yellow	LED SKS (output X09/1,2)	LED ON LED OFF	SKS is OK SKS is interrupted
D016	green	LED charge maintenance	LED ON LED OFF	Storage battery is charged, maintenance phase Storage battery is charging
D017	yellow	LED charge status	LED ON LED OFF	Charging period Not in a charging period - battery charged
D018	red	LED battery fault	LED ON LED OFF	Battery defective, CHANGE BATTERY! Battery OK

9.6 Diagnostic LED D019 F101

Code D 019, colour red

Diagnostic LED (red)	Error / status / info	Action
Flashes once	Battery fault	Rechargeable battery is defective: replace
Flashes 2 times	Mains power failure	Battery charger Def.; FS 101 fuse F2 Def.
Flashes 3 times	Command received from fire alarm or from T1, the door will close	
Flashes 4 times	Door has been closed by the fire alarm or by T1	
Flashes 5 times	Safety circuit input X03/1+2 has been interrupted	Check the safety circuit of the door operator
Flashes 6 times	HY leak (version FS 345 HY))	Check the hydraulic system
Flashes 7 times	SKS defective at OPEN end position	Check SKS
Flashes 8 times	Door has been closed due to an error	

Error diagnosis CS 300 FS

Code	Colour	Description		Error diagnosis
H4	green	LED closing edge safety device	LED ON LED OFF	OK - Closing edge safety device interrupted - Closing edge safety device defective

Fault / error message	Cause	Rectification
System does not respond	- No voltage supply	Check the voltage supply to the operator and the control
Door travels to the CLOSED end position when the UP button is pressed	- Rotating field is connected wrongly	- Check the rotating field and set to clockwise rotating field, if necessary
ERROR END POS.	- The OPEN and CLOSED limit switches are both open, although at least one limit switch should be closed	Check the connection at X11 Check the limit switch connections Check the limit switch settings
ERROR RUNTIME	The programmed running time has been exceeded	Check the path of the door Re-programme the running time
ERROR SKS	The closing edge safety edge is faulty The closing edge safety device was activated	Check the closing edge safety device and the spiral cable Remove obstruction from path of door
ERROR PRESSURE SWITCH TESTING	The pressure sensor is not triggered at the CLOSED end position	Check the pressure sensor, spiral cable and profile Check the setting for the CLOSED end position
Battery Standby	No mains power supply Emergency operation	Check mains power supply (L, N)

Overview of functions

9.7 Adjustment options for TIME 1 (door closes if the mains supply fails)

With timer 1, the control can delay the automatic closing of the door after mains power failure by a set period. When set to 0, the door does not close automatically in the event of mains failure.

If the timer is set to 0 and the mains supply is cut off for a longer period, the deep discharge protection system for the control comes into play. See 17.1.

- 0 - No automatic closing in the event of mains failure
- 1 - In the event of a power cut: closes after 5 seconds
- 2 - In the event of a power cut: closes after 15 seconds
- 3 - In the event of a power cut: closes after 30 seconds
- 4 - In the event of a power cut: closes after 1 minute
- 5 - In the event of a power cut: closes after 2 minutes
- 6 - In the event of a power cut: closes after 5 minutes
- 7 - In the event of a power cut: closes after 15 minutes
- 8 - In the event of a power cut: closes after 30 minutes
- 9 - In the event of a power cut: closes after 60 minutes



9.8 Automatic mode with active closing edge safety device in emergency operation

It is possible to monitor emergency operation with a contact bar. If the contact bar is triggered, the door stops in emergency operation. After the contact bar is free again and a delay of 2 seconds has elapsed, emergency closing is continued. Reversing does not take place. The function of the closing edge safety device (SKS) is checked in the upper end position. If a discernible error is detected, emergency operation takes place without an evaluation of the SKS.

Prerequisites:

- CS 300 FS is connected to FS 101 (see drawing)
- Relay mode 19 is set for relay 4 (factory setting)
- FS 101 DIP switch 4 is ON (switch off mains voltage and battery power)
- CESD (SKS) is connected to terminal X4 of CS 300 FS

Connection between CS 300 FS + FS 101

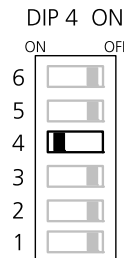
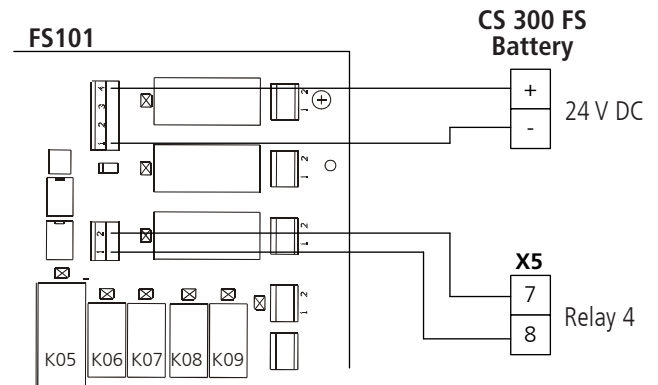

9.9 Emergency closing with 400 V DC operator

It is possible for the door to be closed using the door operator when the fire alarm is activated.

Prerequisites:

- Connect CS 300 X3/9+10 to FS 101 X04/5+6.
- FS 101 DIP switch 3 is ON (switch off mains voltage and battery power)

Connect CS 300 FS circuit board +

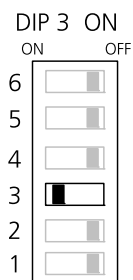
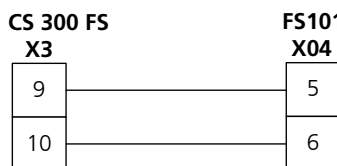

In this case, if a signal is given by the fire alarm and mains power is available, the FS 101 circuit board gives a DOWN impulse [] X3 to the CS 300 FS circuit board via terminal X06. The door is driven to the CLOSED end position in impulse mode. The safety devices integrated are active. Once the CLOSED end position has been reached, the door cannot be opened again.

If the CESD (SKS) is activated during the closing phase, the door reverses and stops at the OPEN end position. After 30 seconds a further DOWN impulse is sent. If the CESD (SKS) interrupts the closing phase again, the process is repeated 3 times in total. If the CLOSED end position has not been reached after 90 seconds, the door is then closed via emergency operation mode.

9.10 Door sealing function for FT fire door operators

To ensure that the sections of the door close together tightly in emergency mode, the door must be driven beyond the CLOSE limit switch.

With the FS 345 control, this function is time controlled and is set using TIMER 2. A value of 0 to 5 seconds can be selected.

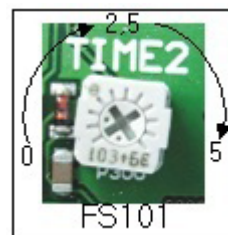

Prerequisites:

- Door operator type FT (DIP 1 is set to ON)
- The system has been set in operation and the limit switches have been set.

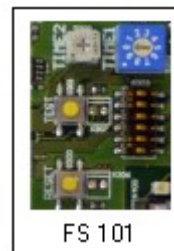

Settings:

1. OPEN and CLOSE limit switches are set for normal door operation.
2. Set timer 2 to the mid-range value of 2.5 seconds.
3. Drive the door to the OPEN end position.
4. Switch off the mains voltage supply and press the TEST button.
5. The door runs to the CLOSED end position in emergency operation mode.
6. The door is then driven beyond the CLOSE limit switch for 2.5 seconds. Only then is power supplied to the motor brake again and the door is held in position.
7. Repeat steps 2 to 6 entering different values for timer 2 until optimum results are achieved.
8. The CLOSE safety limit switch must be set accordingly.

Overview of functions

9.11 Integrated buzzer and RESET button

The FS 345 control unit has an integrated buzzer that gives an acoustic signal to indicate emergency operation and the condition of the rechargeable battery.

The buzzer sounds during emergency closing and stops when it reaches its CLOSED end position.

The alarm also sounds if a faulty battery is detected during operation or during a test.

The acoustic warning signal can also be switched off using the RESET button in the CLOSED door position. The battery needs to be changed.



Buzzer

1 tone sounds at intervals of 5 seconds	No mains voltage
1 tone sounds at intervals of 2 seconds	Rechargeable battery is defective
4 short tones	Warning before emergency closing
1 tone sounds at intervals of a second	Emergency closing

10. Rechargeable battery and battery charger

The FS 345 control unit affords protection against deep discharge of the battery and can carry out regular tests to check the condition of the battery.

10.1 Checking the rechargeable battery and emergency operation

To ensure that the system always functions consistently, the fire alarm function must be checked once every four weeks. In order to check at the same time that the rechargeable battery also functions correctly, the control must be disconnected from the mains. This is the only way to demonstrate that the emergency function is operational and that the door closes automatically via the auxiliary motor.

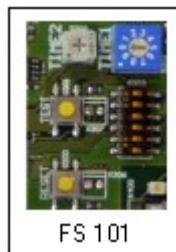

Procedure:

- Drive the door to the OPEN end position.
- Switch off the mains power supply.
- Press TEST button: Emergency operation is started after a delay of 2 seconds.

Check:

after pressing the TEST button

1. the battery test is started LED indicator

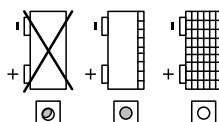

2. The integrated buzzer sounds
3. After 2 seconds, the door is driven to the CLOSED end position
4. The buzzer stops
5. LED indicator

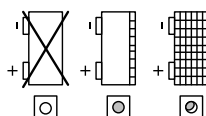

6. The buzzer sounds once
7. The test is over

10.2 Protection against deep discharge

If, following initial operation, the control is operated for a lengthy period without an external power supply, the control is switched off after a defined period to prevent deep discharging of the battery. The period of time depends on the type of operator and so from the external consumer devices.

- DIP 1 ON Switches off after 8 hours without external mains supply voltage
- DIP 1 OFF Switches off after 48 hours without external mains supply voltage

The buzzer sounds continuously for 60 seconds to signal that the battery, and therefore also the control unit, has been switched off.

If timer 1 is to be set to nought (door does not close if mains power fails), the door closes in a controlled manner or is left open depending on the setting of DIP switch 5. It is only possible to keep the door open in a controlled way if DIP switch 1 is OFF:

- DIP 5 ON Door closes after the signal buzzer sounds, the battery/control is switched off
- DIP 5 OFF Door remains open, the battery/control is switched off

The control can only be switched on again if the external voltage supply is reconnected.

For FT types of operator (DIP 1 ON), if the mains supply has been interrupted for a period of 8 hours or longer, the battery is charged for 30 minutes as soon as the mains voltage is switched back on. The door control cannot operate during this charging period. This charging status is indicated via the recharge LED and can be interrupted by pressing the RESET button.

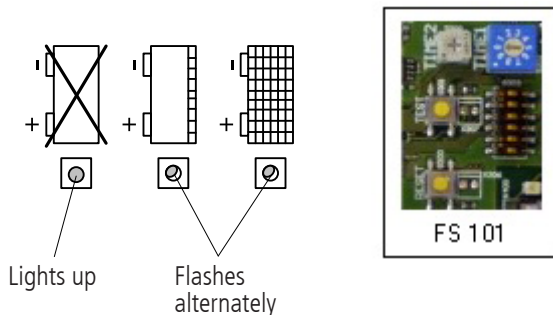

10.3 Cyclic testing of the rechargeable battery

The FS 345 control is able to test the condition of the rechargeable battery automatically. In normal operation, the battery is disconnected from the control every 60 minutes and the battery voltage is checked.

If the battery voltage falls below a specified value (19 V), this is recognised as a fault, which is then indicated via the fault relay, the buzzer and the diagnostic LED. It could be that proper operation in emergency mode is then no longer possible.

DIP switch 5 can be set to specify whether the door closes or stays open in this case.

- DIP 5 ON The door closes, the battery is switched off
- DIP 5 OFF Door remains open, the battery/control is switched off

Connection between CS 300 FS + FS 101

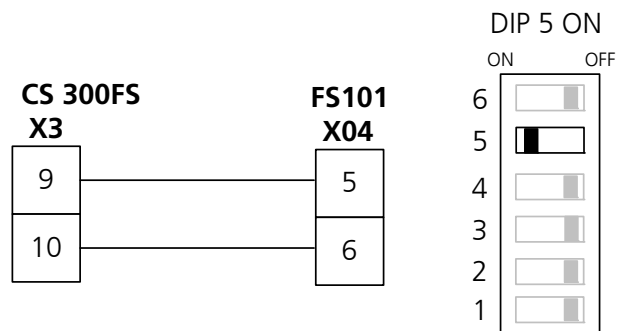

Battery and battery charger

10.4 Recharging the battery



NOTICE

Incorrect charging of maintenance-free lead batteries may result in faults or failures!

Before not using for any length of time (two options)

- Disconnect your battery from the charger and store the battery in its fully charged state

(if not using for more than three months, charge for at least 36 hours)

- You can continue to charge your battery indefinitely with the battery charger switched on (maintenance charging). We recommend storing the batteries in a cool room.

High temperatures

Charging the battery at temperatures of over 30°C is not recommended. Your battery charger is factory set to a charging voltage which is designed for an ambient temperature of 20°C.

Low temperatures

Charging the battery at temperatures under 10°C is not recommended. At low temperatures, the available capacity is reduced.

Deep discharge

Please avoid deep discharging of your battery. If deep battery discharge occurs, however, replace the battery immediately.



CAUTION!

Risk of injury through use of charging devices!

- (due to the formation of *explosive gases when charging lead-acid batteries*)
- Danger of fire and short-circuit (*due to electric shock in moist conditions*)

To prevent any danger:

- Ensure that the area is adequately ventilated.
- Avoid fire and naked lights.
- Use the plug-in power pack only in dry rooms.
- Protect the device from moisture.



NOTICE

Damage due to improper use of charging device!

The FS 101 circuit board charger is suitable for charging maintenance-free lead batteries only.

The battery charger may only be opened by authorised persons and must only be used if closed.

The warranty will be invalid if the charging device becomes damaged due to improper opening.

Ensure that there is adequate ventilation before using the device for the first time.

The device must only be used in closed rooms and must not be exposed to dampness and humidity.

Alterations of any kind to the device will invalidate the warranty.

11. Motor brake and auxiliary motor

11.1 Motor brake connection diagram for FT 3 / FT 4 / FT 5 operator

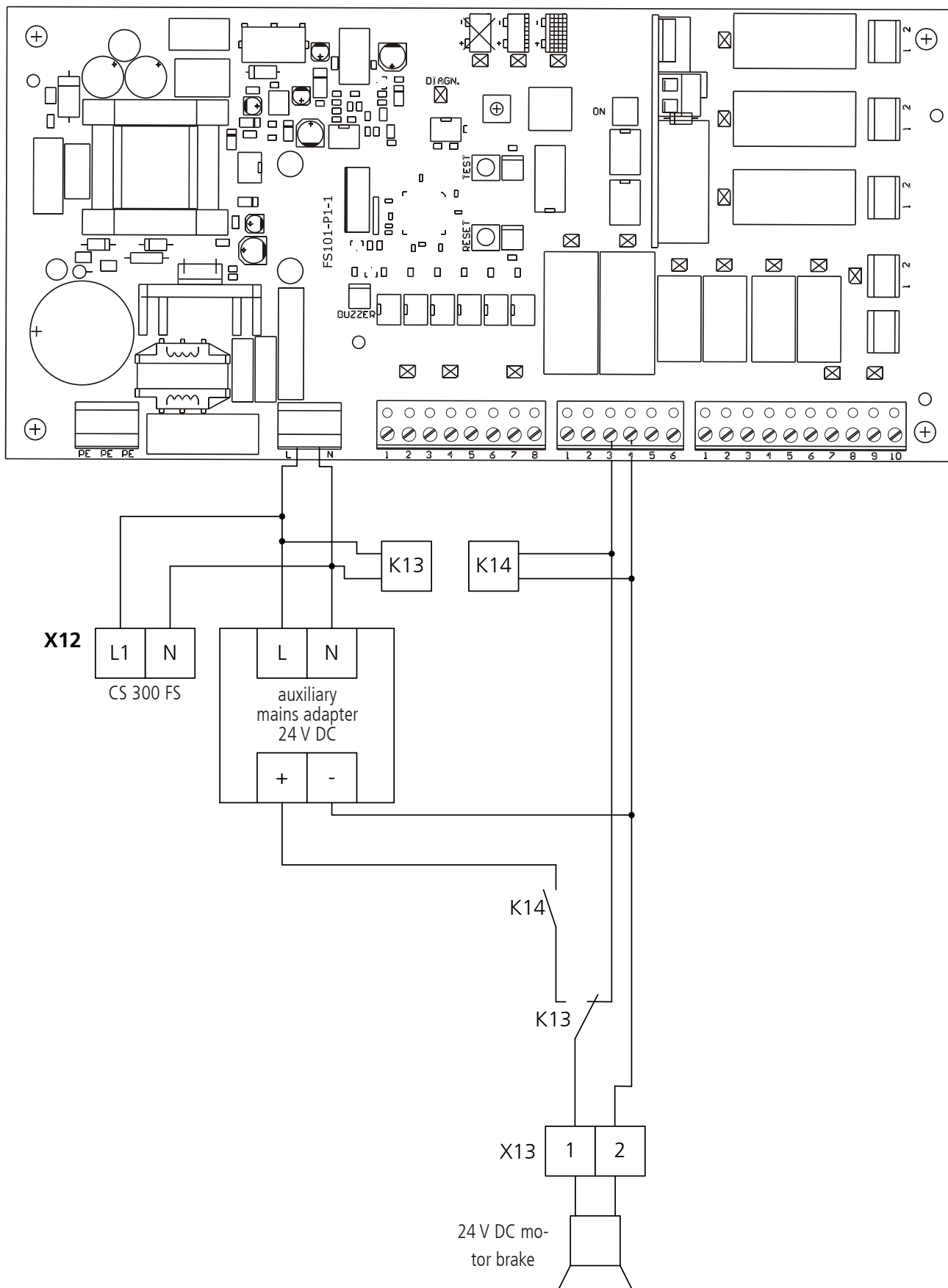

11.2 Auxiliary motor connection diagram for FDF 60 operator

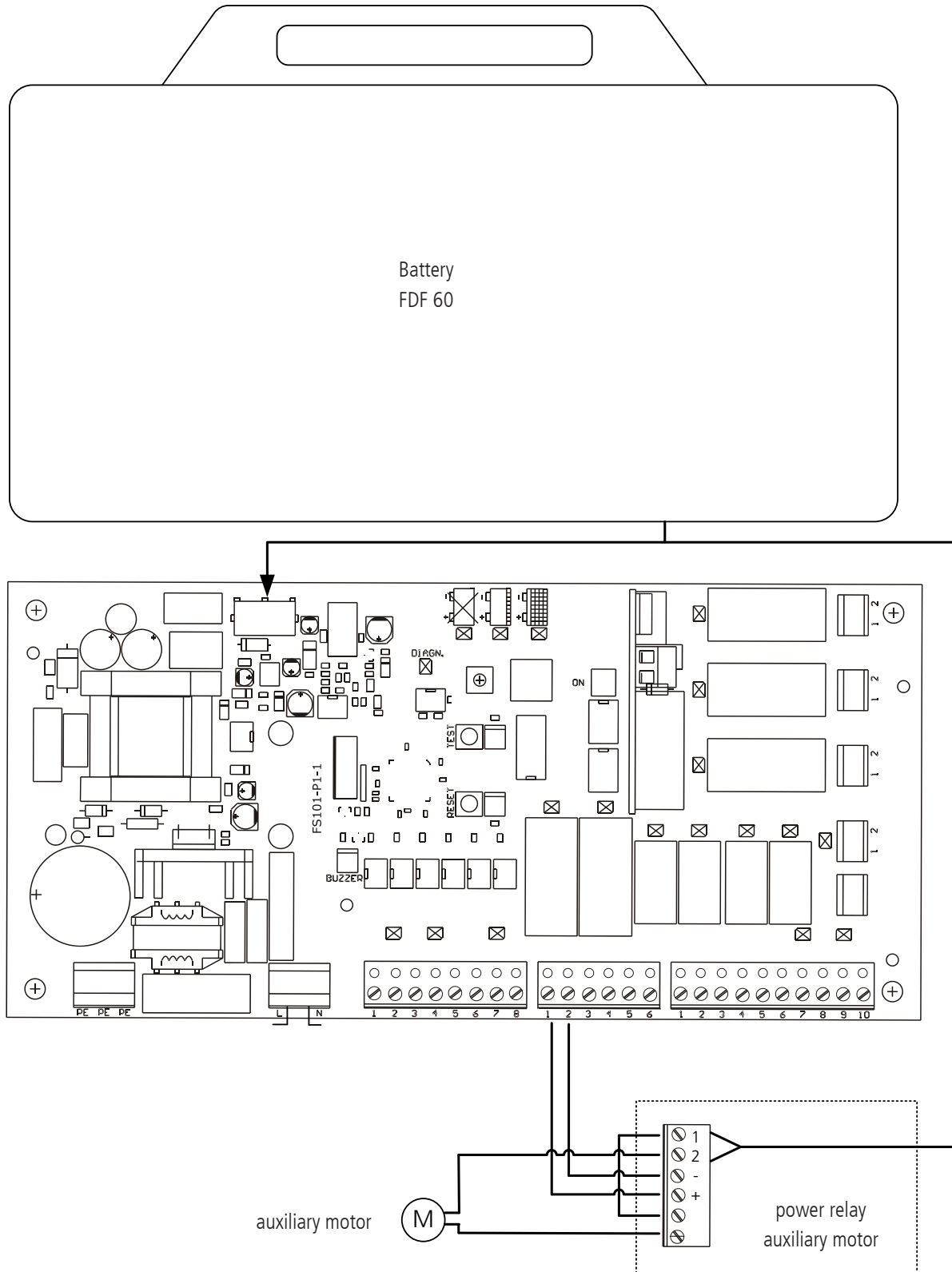

12. Technical data

12.1 Mechanical and electrical data

Housing dimensions:	750 x 300 x 132 mm
Installation:	Vertical mounting on the wall, minimum height above floor = 1,100 mm
Supply voltage:	3~ 400 V AC, 50 Hz, +/- 10% STANDARD 3~ 230 V AC, 50 Hz, +/- 10% SPECIAL SOLUTION Other voltages on request
Fuse protection:	10 A K type
Power input:	Max. 2.2 kW
Internal consumption of control:	Max. power consumption of the CS 300 FS control itself = 250 mA on secondary side Max. power consumption of the FS 101 control itself = 200mA on secondary side
Motor data:	max. 2.2 kW AC / -3.2 A.
Control voltage:	24 V DC, all input connections must be potential-free; minimum signal duration for input control command >100 ms
Control outputs:	24 V DC, maximum of 500 mA
Batteries	Maintenance-free batteries with VdS certification
Fault output relay:	If inductive loads are connected (e.g. further relays or brakes), these must be fitted with appropriate suppressor elements (recovery diodes, varistors, RC circuits). Potential-free normally open contact; min. 10mA ; max. 230 V 230V AC ~ 4A Once contacts have been used for power circuits, they can no longer be used for extra-low current circuits.
Emergency operation output relay:	If inductive loads are connected (e.g. further relays or brakes), these must be fitted with appropriate suppressor elements (recovery diodes, varistors, RC circuits). Potential-free normally open contact; min. 10mA ; max. 230 V 230V AC ~ 16A Once contacts have been used for power circuits, they can no longer be used for extra-low current circuits.
Temperature range:	Operation: +5°C ... +55°C Storage: -20°C ... +85°C
Air humidity:	Up to 80% with no condensation
Vibrations:	Low-vibration mounting, e.g. on a masonry wall
Type of protection:	IP 54
Weight:	approx. 10.5 kg

13. Maintenance

The FS 345 control is maintenance-free.

DANGER!

Life-threatening danger due to electric shock!

-  The control unit or door system MUST be disconnected from the electricity supply before carrying out any electrical work. Take measures to ensure that the power supply remains disconnected for the duration of the work.

The following points must be taken into account when carrying out maintenance on the door system:
Maintenance must only be carried out by authorised persons.
Directive ASR A1.7 must be complied with.
Worn or faulty parts must be replaced.
Only approved parts may be installed.
All maintenance work must be documented.
Replaced fault parts must be disposed of properly in accordance with the materials they contain and local regulations.

14. EC Declaration of Incorporation

We hereby declare that the product described below:

FS 345 Door Control

is in conformity with all essential requirements of the Machinery Directive 2006/42/EC.

In addition, the partly completed machinery is in conformity with all regulations of the EU Construction Products Regulation No. 305/2011, the Electromagnetic Compatibility Directive 2004/108/EC and the Low Voltage Directive 2006/95/EC.

The following standards were applied:

EN 60204-1

Safety of machinery, electrical equipment of machines; Part 1: General requirements

EN ISO 12100

Safety of machinery – general principles for design - risk assessment and risk reduction

DIN EN 12453

Safety in use of power operated doors - Requirements

DIN EN 61000-6-2

Electromagnetic compatibility (EMC) - Part 6-2: Generic standards - Immunity for industrial environments

DIN EN 61000-6-3

Electromagnetic compatibility (EMC) - Part 6-3: Generic standards - Emission - standard for residential, commercial and light-industrial environments

DIN EN 60335-1

Household and similar electrical appliances - Safety - Part 1: General requirements

DIN EN 60335-2-103

Household and similar electrical appliances - Safety - Part 2-103: Particular requirements for drives for gates, doors and windows

The relevant technical documentation is compiled in accordance with Annex VII (B) of the EC Machinery Directive 2006/42/EC. We undertake to transmit, in response to a reasoned request by the market surveillance authorities, this information in electronic form within a reasonable term.

The authorized representative for the compilation of the technical documentation is the undersigned.

The machinery is incomplete and must not be put into service until the machinery into which it is to be incorporated has been declared in conformity with the provisions of the Machinery Directive 2006/42/EC.

Place / Date:

Legden, 01/03/2014

Manufacturer's signature



Dirk Wesseling

Position of signatory

Management

